

TRUCK BRAKE WASHER BCE-400

Cleans brakes of heavy-duty tactical vehicles, commercial trucks and off-highway equipment serviced on safety stands.



Low Profile

Only 11" (28 cm.) high; easily rolls under truck axles

Handle folds down so it doesn't interfere when washer is being used.

Compressed Air Powered

No electricity required

Deploys with unit and operates in the field using the compressed air from tactical vehicles

COMPLYS WITH OSHA ASBESTOS REGULATION 29 CFR 1910.1001

OSHA-preferred, low pressure brake washing system eliminates exposure to airborne brake dust during drum removal and brake cleaning.

National Stock Number

NSN 4910-01-421-8469

Capacity

6.5 gallons (25 L)

BackBuddy™ Compatible

PN 400-012 Riser Kit elevates the basin to allow room for the Back Buddy's™ front wheels to roll under the dolly.



575 Prospect Street, Unit 213 • Lakewood, NJ 08701-5040 USA

CLAYTON

+1 (800) 248-8650

+1 (732) 363-2100

Fax +1 (732) 364-6084

www.jclayton.com

BCE-400

Designed to meet the demanding requirements of the U.S. Military



BCE-400 Truck Brake Washer

Consists of model BCE-410 plus a 5 gallon (19 L) pail of T-N-T™ Plus.

T-N-T Plus™ Concentrated Cleaner

T-N-T™ Plus is non-toxic, non-flammable, biodegradable and derived from natural sources. Two (2) liters of concentrate make 6.5 gallons (25 L) of potent cleaning solution.

Primary Microfilter

This 15 micron efficiency cloth filter extends the useful life of the cleaning solution.

Large work area:

23" X 21.25" X 8" (58 cm. x 54 cm. x 20 cm.) basin is large enough to catch the run-off of liquid from large truck drums. The vinyl-clad grill will support up to 200 pounds (90 kg.)

Prefilter

Extends the life of the Primary Microfilter by collecting heavy dirt and debris that accumulates in and on the drums during off-highway maneuvers. Constructed of durable polyethylene plastic frame with stainless steel filter media.

Safety Drying Gun

After cleaning technicians can dry the brakes before applying lubricating the shoes.

No time is lost waiting for water-based cleaners to dry.

Injector Nozzle

15" (38 cm.) flexible wand is long enough to reach behind large truck tires to flush the drum before removing the it. Suppressing the dust before removal prevents exposure to hazardous brake dust even when considerable force is needed to free the drum.

Cover

The flexible cover doubles as a drain board to direct run-off from the brakes back into the basin.

Air Powered Pump

Requires no electricity. Can be operated in the field using compressed air from the truck's compressor. After removing the tires, the technician connects the air supply hose to the washer to begin cleaning.

Flow-Thru Brush

New parts cleaning brush features stiff, durable bristles for extended life and vigorous cleaning action. Double-shut-off quick disconnect coupling

Air Regulator

Limits air pressure to 32 PSI (2.2 bar); eliminates the need to adjust or otherwise regulate shop air pressure.

BCE-410 Truck Brake Washer

Consists of the items shown below:

(1) Oil-Magnet™, (1) Cover, (1) Dolly, (1) Basin, (1) Prefilter and (3) Primary Microfilters.

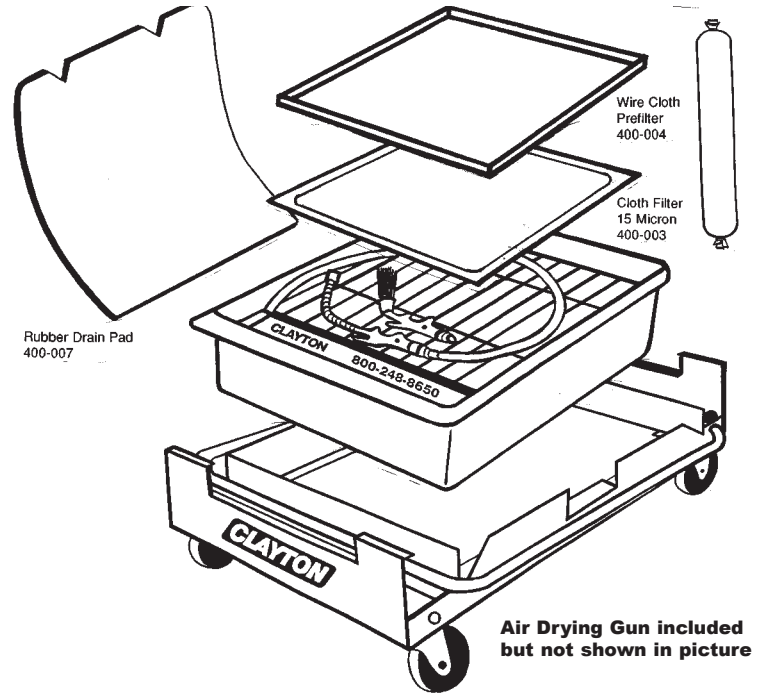

SPECIFICATIONS

Basin

Overall: 25" L x 24" W x 8" H (64 cm. x 61 cm. x 20 cm.)
6.5 gallon (25 L) capacity
Polyethylene construction
Oil-Magnet™ reusable, retains 2 liters of oil,

Dolly

34" L x 22" W x 11" H (86 cm. x 56 cm. x 28 cm.)
Industrial-grade casters - 4" (10 cm.)
Galvanized steel construction - .090" (2.3 mm.)
Handle - 1" (2.54 cm.) diameter stainless steel

575 Prospect Street, Unit 213 • Lakewood, NJ 08701-5040 USA

CLAYTON

1-800-248-8650

1-732-363-2100

FAX 1-732-364-6084

www.jclayton.com