

BRAKE WASHER CATALOG

America's favorite vehicle brake washers pay for themselves in months by eliminating the need for rental brake washers and aerosol cleaners.

MACHINES COMPLY WITH OSHA ASBESTOS REGULATION 29 CFR 1910.1001

OSHA-preferred, low pressure brake washing system eliminates exposure to airborne brake dust during drum removal and brake cleaning.

CareFree Disposal System™

Solid waste: As simple as throwing out the trash.
Wastewater: Follow operating instructions and just pour it down the drain. Disposal Guidebook included with each machine.

ECONOMICAL

Clean all four brakes on 30 cars for less than the cost of one can of aerosol brake cleaner.

Safety Drying Gun

After cleaning technicians can dry the brakes before applying lubricating the shoes.

No time is lost waiting for water-based cleaners to dry.



NATIONAL STOCK LISTED

BCE-300 NSN # 4940-01-396-0573

BCE-400 NSN # 4910-01-421-8469



575 Prospect Street, Unit 213 • Lakewood, NJ 08701-5040 USA

CLAYTON

+1 (800) 248-8650

+1 (732) 363-2100

Fax +1 (732) 364-6084

www.jclayton.com

MINI BRAKE WASHER BCE-200

Perfect for motorcycles, bikes, golf carts, personnel & burden carriers and cars serviced on safety stands or ramp-style lifts



Lightweight & compact

Only 8" (20 cm.) high, machine can be placed on ramps of drive-on lifts or, placed on a tool cart for servicing vehicles on single or two-post lifts.

Compressed Air Powered

No electricity required

Military units can operate the washer in the field using the compressed air from tactical vehicles.

COMPLYS WITH OSHA ASBESTOS REGULATION 29 CFR 1910.1001

OSHA-preferred, low pressure brake washing system eliminates exposure to airborne brake dust during drum removal and brake cleaning.

Includes Cover

Optional cover latches available

Capacity

3.5 gallons (13 L)

Air Drying Gun

No need to wait for brakes to dry. Using the attached air drying gun, technicians can quickly dry brakes before applying lubricant

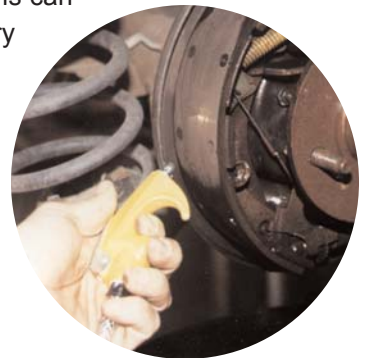

575 Prospect Street, Unit 213 • Lakewood, NJ 08701-5040 USA

CLAYTON

+1 (800) 248-8650

+1 (732) 363-2100

Fax +1 (732) 364-6084

www.jclayton.com

BCE-200

BCE-200 Mini Brake Washer

Consists of (1) Oil-Magnet™, (1) Cover, (1) Basin and (1) Primary Microfilters.

Primary Microfilter

15 micron efficiency cloth filter extends the useful life of the cleaning solution. This durable cloth filter can be washed and used repeatedly before disposal.

Large work area:

basin is large enough to catch the run-off of liquid from trucks or cars of all sizes. The vinyl-clad grill with support up to 200 pounds (90 kg.)

Safety Drying Gun

After cleaning technicians can dry the brakes before applying lubricating the shoes.

No time is lost waiting for water-based cleaners to dry.

Air Powered Pump

Requires no electricity. Can be operated in the field using compressed air from the truck's compressor.

After removing the tires, the technician connects the air supply hose to the washer to begin cleaning.

Flow-Thru Brush

New parts cleaning brush features stiff, durable bristles for extended life and vigorous cleaning action. Double-shut-off quick disconnect coupling

Air Regulator

Limits air pressure to 32 PSI (2.2 bar); eliminates the need to adjust or otherwise regulate shop air pressure.

Injector Nozzle

9" (23 cm.) flexible wand is used to flush the drum before removing the it. Suppressing the dust before removal prevents exposure to hazardous brake dust even when considerable force is needed to free the drum.

T-N-T Plus™ Concentrated Cleaner

T-N-T™ Plus is non-toxic, non-flammable, biodegradable and derived from natural sources. 330 ml of concentrate make 3.5 gallons (13 L) of potent cleaning solution.

SPECIFICATIONS

Basin

Overall: 22" X 14.75" X 8" (56 cm. x 37 cm. x 20 cm.)

3.5 gallon (13 L) capacity

Polyethylene construction

Oil-Magnet™ reusable, retains 2 liters of oil,

CareFree Disposal System™

In most parts of the world, waste water from the basin can be disposed of in the sanitary sewer.

Filters can be disposed of as ordinary shop waste.

Consult local authorities for information regarding disposal in your area.

575 Prospect Street, Unit 213 • Lakewood, NJ 08701-5040 USA

CLAYTON

1-800-248-8650

1-732-363-2100

FAX 1-732-364-6084

www.jclayton.com

SUPER BRAKE WASHER BCE-300

America's original brake washer pays for itself in months by eliminating the need for rental brake washers and aerosol cleaners.

COMPLYS WITH OSHA ASBESTOS REGULATION 29 CFR 1910.1001

OSHA-preferred, low pressure brake washing system eliminates exposure to airborne brake dust during drum removal and brake cleaning.

Air Regulator

Limits air pressure to 32 PSI (2.2 bar); eliminates the need to adjust or otherwise regulate shop air pressure.

ECONOMICAL

Clean all four brakes on 30 cars for less than the cost of one can of aerosol brake cleaner.

Construction

Broad-based dolly keeps the unit stable.
Steel-reinforced undercarriage makes it very strong.
Large industrial-strength casters make for easy movement throughout the shop.
Polyethylene plastic will not rust, chip or dent.
Welded construction stands up to the daily rigors and rough handling common to vehicle repair facilities.

Cover

Cover stored on dolly (shown left of drum in right photo).

Cover doubles as a catch-basin when servicing vehicles on safety stands.

CareFree Disposal System™

Solid waste: As simple as throwing out the trash. Wastewater: Follow operating instructions and just pour it down the drain. Disposal Guidebook included with each machine.

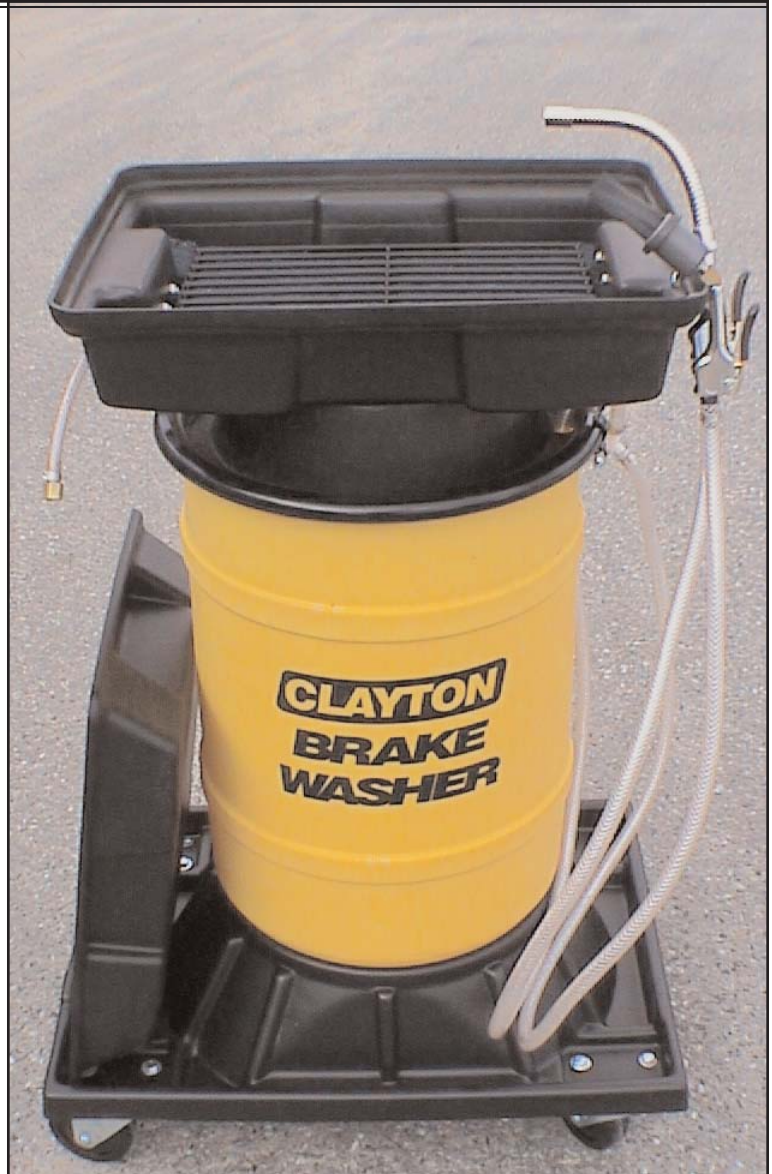

National Stock Number

NSN 4940-01-396-0573

575 Prospect Street, Unit 213 • Lakewood, NJ 08701-5040 USA

CLAYTON

+1 (800) 248-8650

+1 (732) 363-2100

Fax +1 (732) 364-6084

www.jclayton.com

BCE-300

SealTite™ Primary Microfilter

This 15 micron efficiency filter extends the useful life of the cleaning solution. A molded, self-sealing collar fits securely into the basin to prevent particles from bypassing the filter. For best results, this disposable filter is changed monthly or approximately every 150 vehicles.

Basin:

21" X 16" X 4 1/4" (53 cm. x 41 cm. x 11 cm.) basin provides ample room to loosen, remove and clean car and light truck drums.

Splash-Gard™ Pad

This fiber pad keeps liquid running off the brakes from splashing on the floor. It also serves as a prefilter to remove coarse particles from the solution and prevent small brake parts from becoming lost in the Primary Microfilter.

Grille

Vinyl-clad grille supports the brake drum and parts during cleaning and protects the Splash-Gard™ pad.

T-N-T Plus™ Concentrated Cleaner

T-N-T™ Plus is non-toxic, non-flammable, biodegradable and derived from natural sources. One liter of concentrate makes 10 gallons (38 L) of potent cleaning solution. Each machine comes with a liter of T-N-T™ Plus concentrate, one Primary Microfilter and one Splash-Gard™ pad.

Flow-Thru Brush

New parts cleaning brush features stiff, durable bristles for extended life and vigorous cleaning action.



Injector Nozzle

Flexible wand to flush the drum before removing it. Suppressing the dust before removal prevents exposure to hazardous even if a hammer is needed to free the drum.

Air Powered Pump

Eliminates the risk of electrical shock. After removing the tires, the technician connects the air supply hose to the washer to begin cleaning.

Basic Starter Kit PN 300-102

Recommended for purchase with a new machine, this kit consists of 8 Primary Microfilters, 8 disposal bags and 2 liters of T-N-T™ Plus.

Basic Supply Kit PN 300-152

Recommended for purchase after the first year of use, this kit contains approximately one year's usage of supplies: 9 Primary Microfilters, 9 disposal bags, 3 liters of T-N-T™ Plus, one brush tip and one Splash-Gard™ pad.

575 Prospect Street, Unit 213 • Lakewood, NJ 08701-5040 USA

CLAYTON

sales@jclayton.com

+1 (732) 363-2100

FAX +1 (732) 364-6084

www.jclayton.com

TRUCK BRAKE WASHER BCE-400

Cleans brakes of heavy-duty tactical vehicles, commercial trucks and off-highway equipment serviced on safety stands.



Low Profile

Only 11" (28 cm.) high; easily rolls under truck axles

Handle folds down so it doesn't interfere when washer is being used.

Compressed Air Powered

No electricity required

Deploys with unit and operates in the field using the compressed air from tactical vehicles

COMPLYS WITH OSHA ASBESTOS REGULATION 29 CFR 1910.1001

OSHA-preferred, low pressure brake washing system eliminates exposure to airborne brake dust during drum removal and brake cleaning.

National Stock Number

NSN 4910-01-421-8469

Capacity

6.5 gallons (25 L)

BackBuddy™ Compatible

PN 400-012 Riser Kit elevates the basin to allow room for the Back Buddy's™ front wheels to roll under the dolly.



575 Prospect Street, Unit 213 • Lakewood, NJ 08701-5040 USA

CLAYTON

+1 (800) 248-8650

+1 (732) 363-2100

Fax +1 (732) 364-6084

www.jclayton.com

BCE-400

Designed to meet the demanding requirements of the U.S. Military



BCE-400 Truck Brake Washer

Consists of model BCE-410 plus a 5 gallon (19 L) pail of T-N-T™ Plus.

T-N-T Plus™ Concentrated Cleaner

T-N-T™ Plus is non-toxic, non-flammable, biodegradable and derived from natural sources. Two (2) liters of concentrate make 6.5 gallons (25 L) of potent cleaning solution.

Primary Microfilter

This 15 micron efficiency cloth filter extends the useful life of the cleaning solution.

Large work area:

23" X 21.25" X 8" (58 cm. x 54 cm. x 20 cm.) basin is large enough to catch the run-off of liquid from large truck drums. The vinyl-clad grill will support up to 200 pounds (90 kg.)

Prefilter

Extends the life of the Primary Microfilter by collecting heavy dirt and debris that accumulates in and on the drums during off-highway maneuvers. Constructed of durable polyethylene plastic frame with stainless steel filter media.

Safety Drying Gun

After cleaning technicians can dry the brakes before applying lubricating the shoes.

No time is lost waiting for water-based cleaners to dry.

Injector Nozzle

15" (38 cm.) flexible wand is long enough to reach behind large truck tires to flush the drum before removing the it. Suppressing the dust before removal prevents exposure to hazardous brake dust even when considerable force is needed to free the drum.

Cover

The flexible cover doubles as a drain board to direct run-off from the brakes back into the basin.

Air Powered Pump

Requires no electricity. Can be operated in the field using compressed air from the truck's compressor. After removing the tires, the technician connects the air supply hose to the washer to begin cleaning.

Flow-Thru Brush

New parts cleaning brush features stiff, durable bristles for extended life and vigorous cleaning action. Double-shut-off quick disconnect coupling

Air Regulator

Limits air pressure to 32 PSI (2.2 bar); eliminates the need to adjust or otherwise regulate shop air pressure.

BCE-410 Truck Brake Washer

Consists of the items shown below:

(1) Oil-Magnet™, (1) Cover, (1) Dolly, (1) Basin, (1) Prefilter and (3) Primary Microfilters.

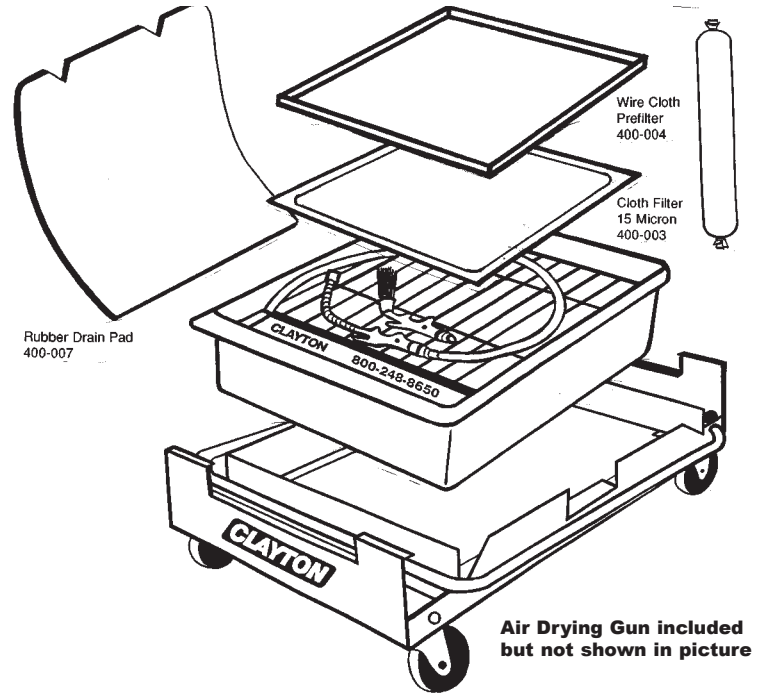

SPECIFICATIONS

Basin

Overall: 25" L x 24" W x 8" H (64 cm. x 61 cm. x 20 cm.)
6.5 gallon (25 L) capacity
Polyethylene construction
Oil-Magnet™ reusable, retains 2 liters of oil,

Dolly

34" L x 22" W x 11" H (86 cm. x 56 cm. x 28 cm.)
Industrial-grade casters - 4" (10 cm.)
Galvanized steel construction - .090" (2.3 mm.)
Handle - 1" (2.54 cm.) diameter stainless steel

575 Prospect Street, Unit 213 • Lakewood, NJ 08701-5040 USA

CLAYTON

1-800-248-8650

1-732-363-2100

FAX 1-732-364-6084

www.jclayton.com

SUPER BRAKE WASHER BCE-500

America's favorite all-vehicle brake washer pays for itself in months by eliminating the need for rental brake washers and aerosol cleaners.

COMPLYS WITH OSHA ASBESTOS REGULATION 29 CFR 1910.1001

OSHA-preferred, low pressure brake washing system eliminates exposure to airborne brake dust during drum removal and brake cleaning.

Air Regulator

Limits air pressure to 32 PSI; eliminates the need to adjust or otherwise regulate shop air pressure.

Drain Spigot

Makes it fast and easy for technicians to empty the tank when changing cleaning solution. Just open the spigot over a floor drain and walk away.

CareFree Disposal System™

Solid waste: As simple as throwing out the trash.
Wastewater: Follow operating instructions and just pour it down the drain. Disposal Guidebook included with each machine.

ECONOMICAL

Clean all four brakes on 30 cars for less than the cost of one can of aerosol brake cleaner.

Safety Drying Gun

After cleaning technicians can dry the brakes before applying lubricating the shoes.

No time is lost waiting for water-based cleaners to dry.

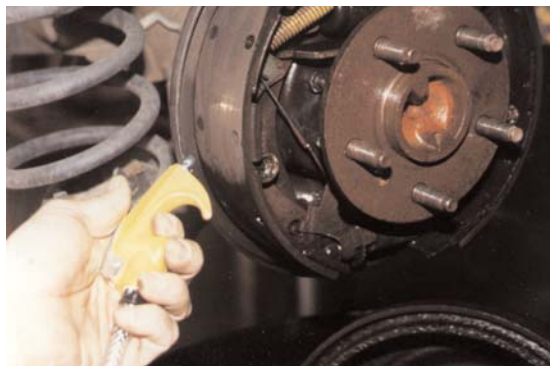

Construction

Broad-based dolly keeps the unit stable.

Steel-reinforced undercarriage makes it very strong.

Large industrial-strength casters make for easy movement throughout the shop.

Polyethylene plastic will not rust, chip or dent.

Welded construction stands up to the daily rigors and rough handling common to vehicle repair facilities.

575 Prospect Street, Unit 213 • Lakewood, NJ 08701-5040 USA

CLAYTON

+1 (800) 248-8650

+1 (732) 363-2100

Fax +1 (732) 364-6084

www.jclayton.com

BCE-500

SealTite™ Primary Microfilter

This 15 micron efficiency filter extends the useful life of the cleaning solution. A molded, self-sealing collar fits securely into the basin to prevent particles from bypassing the filter. For best results, this disposable filter is changed monthly or approximately every 150 vehicles.

Large work area:

26" X 20" X 7" basin provides ample room to loosen, remove and clean car and light truck drums. Deep-draft design keeps solution from splashing onto the floor.

Parts Cleaning Tray

Keeps small parts from entering the filter.

T-N-T Plus™ Concentrated Cleaner

T-N-T™ Plus is non-toxic, non-flammable, biodegradable and derived from natural sources. One liter of concentrate makes 10 gallons (38 L) of potent cleaning solution. Each machine comes with a liter of T-N-T™ Plus concentrate, one Primary Microfilter and one Ultra Filter cartridge.

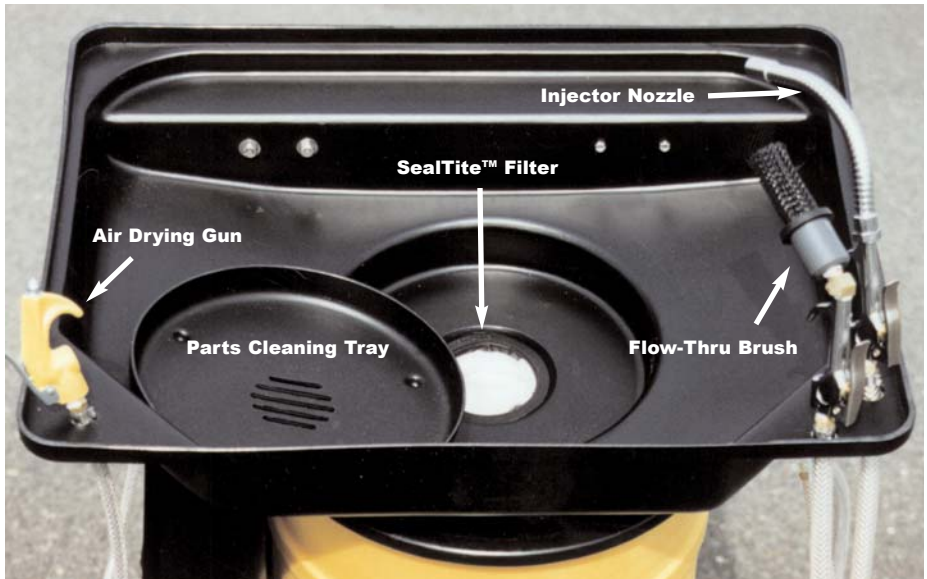

Flow-Thru Brush

New parts cleaning brush features stiff, durable bristles for extended life and vigorous cleaning action.

Injector Nozzle

Flexible wand to flush the drum before removing the it. Suppressing the dust before removal prevents exposure to hazardous even if a hammer is needed to free the drum.

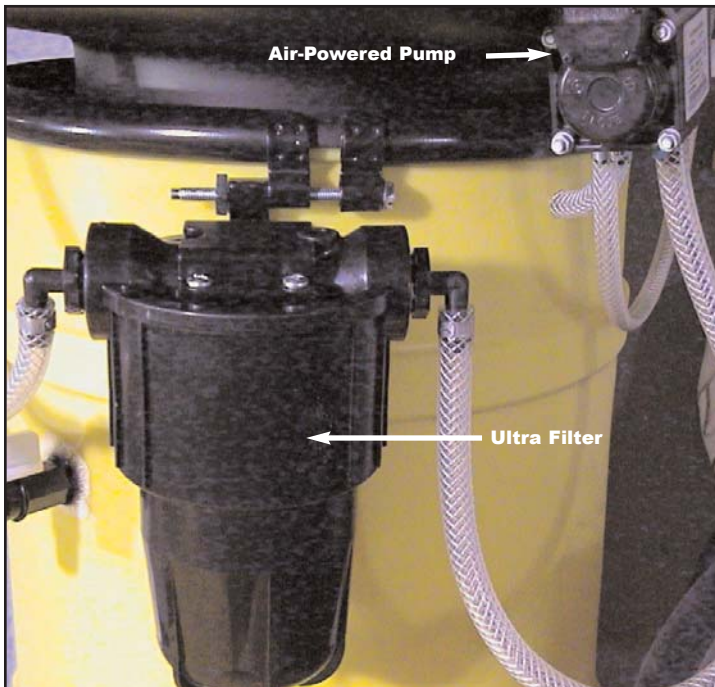

Air Powered Pump

Eliminates the risk of electrical shock. After removing the tires, the technician connects the air supply hose to the washer to begin cleaning.

Ultra Filter

This five (5) micron polishing filter removes small particles from the solution and is typically changed each time the solution is changed, i.e., approximately every 3 months or 450 vehicles.

Ultra Starter Kit PN 500-202

Recommended for purchase with a new machine, this kit consists of 8 Primary Microfilters, 2 Ultra filter cartridges, 8 disposal bags and 2 liters of T-N-T™ Plus.

Ultra Supply Kit PN 500-252

Recommended for purchase after the first year of use, this kit contains approximately one year's usage of supplies: 9 Primary Microfilters, 3 Ultra filter cartridges, 9 disposal bags, 3 liters of T-N-T™ Plus and one brush tip.

575 Prospect Street, Unit 213 • Lakewood, NJ 08701-5040 USA

CLAYTON

sales@jclayton.com

+1 (732) 363-2100

FAX +1 (732) 364-6084

www.jclayton.com

T-N-T PlusTM

WITH TRUE SOLVENT ACTION

- Waterbased
- Biodegradable
- Non hazardous

HAZARD RATING	FIRE	REACTIVITY	HEALTH	PERSONAL
4 = EXTREME	0		1	0
3 = HIGH			X	
2 = MODERATE				
1 = SLIGHT				
0 = INSIGNIFICANT				
X = BLANK				

- Flashpoint over 212° (T.C.C.), in concentrate
- Will not harm friction material or rubber components
- Cost effective
- Low VOC
- Emulsions are not a VOC per EPA method 8240
- Contains a rust inhibitor

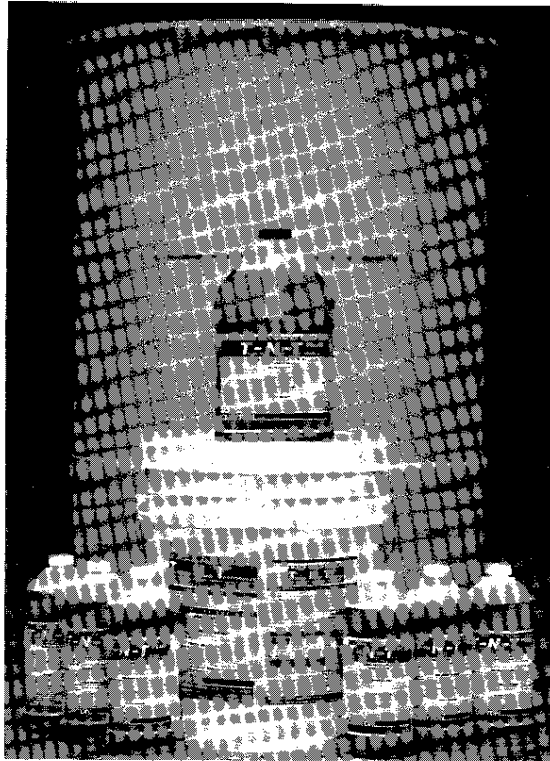

- Leaves no residue
- Low or slight characteristic odor
- Non ozone depleting
- Non carcinogenic
- Non global-warming potential
- Not regulated under the following U.S. Federal Legislation and Regulations
 - a) Clear Water Act
 - b) Clean Air Act
 - c) Resource Conservation and Recovery Act
 - d) Comprehensive Environmental Response, Comprehensive and Liability Act (Superfund)
 - e) The Emergency Planning and Community Right-To- Know Act (SARA TITLE III)

A 10% Solution of T-N-T PLUSTM and Water is Dynamite on Grease and Oil

For many years, terpene (mostly in the form of simple d-limonene products) have been demonstrated to be safe for people and the environment. These citrus products have been used in cleaning applications to replace chlorinated solvents while minimizing regulated emissions to both water and air. As contrasted to d-limonene cleaners of years ago, state of the art terpene cleaning agents now have the advantages of low odor, high flash point (212° F T.C.C.). Other benefits include low residue, low or no VOC emissions, low vapor pressure, minimal waste discharge, and best of all, superior performance.

T-N-T PLUSTM is a synergistic blend of superior surfactants, patented Tarksol 97TM biodegradable terpene solvent, corrosion inhibitors and odor

counteractant. A 10% solution is all it takes to loosen and remove stubborn dirt, grease and oil. No rinsing required.

T-N-T PLUSTM Seems to Last Forever

T-N-T PLUSTM's unique chemistry allows it to keep on working long after competitive cleaners would be exhausted. When T-N-T PLUSTM becomes saturated with oil, it releases it to form an oil cap *over* the solution in the tank. Thus, T-N-T PLUSTM is never overwhelmed by oil as other cleaners are.

PART NO.	ITEM	QTY.	SIZE
300-361	T-N-T PLUS TM CLEANER	6	1 QUART
300-341	T-N-T PLUS TM CLEANER	4	1 GALLON
300-305	T-N-T PLUS TM CLEANER	1	5 GALLON
300-355	T-N-T PLUS TM CLEANER	1	55 GALLON

CLAYTON

Preserving The Earth's Natural Resources - Assuring A Safe Workplace For All

CLAYTON ASSOCIATES, INC. • 490 OBERLIN AVENUE SOUTH • LAKEWOOD, NJ 08701-6903 • 908-363-2100 • 800-248-8650 • FAX 908-364-6084

CSS062B